

Quail Call



February

Sun	Mon	Tue	Wed	Thu	Fri	Sat
	1				5	6
7	8				12 BUSINESS MEETING 7PM	13 SEMINAR Hansen's Garage RAMONA
14 Happy Valentine's Day	15 President's Day				19	20 TOUR
21	22				26 BIG THREE SWAP MEET	27 BIG THREE SWAP MEET
28 BIG THREE SWAP MEET						

QUAIL CALL

EDITOR

Valarie Basham
9271 Huntington Ave.
San Diego, Ca. 92123-3124
(858) 278-6317

E-mail: dcmomof12@aol.com

WEBSITE

www.sdmodelaclub.com

Published monthly by MARC/MAFCA of San Diego.
All articles submitted for publication should reach the editor before the 25th of each month. All articles become the property of MARC/MAFCA of San Diego and are subject to corrections or revisions. Permission granted to reprint articles.

2009 BOARD OF DIRECTORS AND COMMITTEE CHAIRMEN

BOARD OF DIRECTORS

DIRECTOR	Bud Swartwood	(619) 579-6726
ASST. DIR.	Paul Winchester	(619) 669-0737
SECRETARY	Bob Weckman	(858) 279-0596
TREASURER	Roxy Faust	(619) 297-1424
TECHNICAL	Arlyn Bieber	(858) 530-2336
TOURS	Roger Ball	(619) 465-4110
PAST DIR.	Dave Sohr	(619) 440-0374

Board Meetings are held quarterly: see *Quail Call* for dates and location. All member are welcome to attend, just let the host or hostess know you are coming.

COMMITTEE CHAIRMEN

Membership	Roger Phillips	(858) 454-5070
Fashions	Billie Bonnoront	(619) 669-6391
Historian	Penny Smiley	(619) 440-0374
Refreshments	Dalene Jensen	(619) 670-6152
Cor. Secretary	Diane Seeman	(619) 749-5608
Property	Reen Kotas	(858) 278-8178
Ways & Means	Rich Phillips	(619) 670-7843
Rec. Rep.	JudyJo Beardslee	(619) 465-9513
Defender,	Ray Beardslee	(619) 465-9513
Mail-box	Ray Beardslee	(619) 465-9513

CLUB MAILING ADDRESS: P.O. BOX 19805 SAN DIEGO, CA. 92159

BUSINESS MEETING HELD THE 2ND FRIDAY OF EACH MONTH AT 7:00 PM

San Carlos Recreation Center
6445 Lake Badin Ave.

San Diego, Ca. (619) 527-3443

The San Diego Model A Club was first founded in 1957 by a few dedicated Model A owners. Our purpose is to help preserve the Model A, which was in production by the Ford Motor Company from 1928-1931. Ownership of a Model A is not a requirement for membership in the club. Membership dues are \$30.00 per calendar year. Membership in one of the National Clubs is mandatory (either MARC or MAFCA) and the responsibility of each member. Contact information to join a National Club is listed below:



Model A Restorers Club

6721 Merriman Road,
Garden Grove Michigan 48135
(734) 427-9050

E-mail: modelarestorers@sbcglobal.net

Website: www.modelaford.org

Dues are \$38.00 per calendar year.

Model A Ford Club of America

250 S. Cypress Street
La Habra, Ca. 90631-5515
(562) 697-2712

E-mail: info@mafca.com

Website: www.mafca.com

Dues are \$40.00 per calendar year.

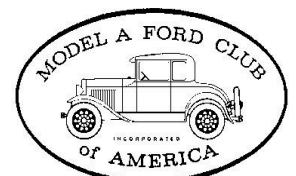

DIRECTOR'S REPORT: Bud Swartwood



The 2010 year is off to quite a start. Our first Tour was delayed a week as the San Diego area experienced wind and rain unlike our usual sunny & warm days. Notification was facilitated by using the Club e-mail site. I encourage you to let either Valarie or me know if you change your e-mail address or add a new e-mail address.

Plans are underway for The National Model A Ford Museum. It will be a part of the Gilmore Car Museum in Hickory Corners, MI. Arlyn Bieber is our Club Liaison. I am sure we will hear more about this exciting venture as the year progresses. Joan Minnick has accepted the task of keeping an inventory of Club merchandise. There are several shirts, some hats, even a couple of jackets currently available. Several items will be available at the meeting. Items not on hand can be ordered. Please plan on pre-paying when ordering a jacket.

Save the dates and plan to attend the following Club events. On February 13, there will be a technical workshop in Ramona. The Palomar Club has been invited to join in the fun. February 20, we will be Touring to Gillespie Field in El Cajon. Model A's and antique airplanes should be a great combination. Plan to attend as we accept the invitation of the San Diego Antique Airplane Association to join them in this event. Specifics for each of these events are in the Quail Call. Check your e-mail for changes or up dates.

I am looking forward to this year as the Club President and encourage your continued in-put and suggestions. I have asked that a 2010 Budget be prepared for the Club Board Meeting in March. A presentation to the membership should be available for the April monthly meeting. Our Club is solid financially. Knowing the sources of income and possible expenses will help all of us keep on track.

INSTALLATION BANQUET Valarie Basham

When we first explored the idea of returning to banquet facilities in Hotels, we were not sure how the club would respond. We were afraid that our numbers may be lower than past years, but that was not the case. We were delighted to receive 90 reservations for this year's banquet. Unfortunately, there were some who were unable to attend at the last minute, and if we go this route next year we will make some adjustments.

In the past, while those of us who have spend hours in the morning setting up tables and decorating, then reversing the process at the end of the night, in addition to hauling out the garbage, were looking forward to a change. At our table, there were a few comments about real dishes this year, no paper plates. Ah, it was much less work for many of us.

I want to thank Burnette Hill for getting the ball rolling, and finding the Crowne Plaza for us. Special thanks to Penny Smiley for the beautiful table decorations, and putting the License plate game together. Dave installed the new board for 2010, and everyone received a lottery ticket as a table favor. No big winners but a few small winners throughout the room. I for one had a wonderful time and have received a number of notes, emails and phone calls from members all with positive response to this year's banquet. While there was some heckling from one table, because their numbers were not being called for door prizes. The last number drawn was none other than the heckler himself and no further harassment have been received. A special thanks to those that donated gifts for the Door Prizes.

*Thanks to all who attended this year, you helped to make the evening a success and if you missed out, mark **Saturday January 15, 2011**, on your calendar that's the date for next year's banquet.*

San Diego Model A Restorers' Club

General Meeting and Installation Banquet January 9, 2010

Meeting was called to order at 8:07 P.M. by Director Dave Sohr, followed by Pledge of Allegiance to the Flag.

Parades: March Ocean Beach Kite Parade

Tours: Roger Ball new Tour Director announced Follow the Leader Tour January 23 with January 30, rain date if necessary. Possible tour related to Air Show at Gillespie Field. Technical Seminar to be held Saturday February 13th, 9:00 A.M. at the Hanson Garage in Ramona to discuss Water Pumps. Notice will appear in Quail Call as a reminder. Nayola Bieber working on another trip to Idyllwild and other tours are in the works.

Treasurer: Bob Weckman asked for a motion to pay the bills. Account balances were read. The check signers for the San Diego Model A Restorers Club in 2010 are: Director-Wilbur B. Swartwood, Secretary-Robert J. Weckman and Treasurer-Roxanna Faust.

Membership Longevity Awards: Ed Woodruff presented Five Year Awards to: Peggy Dalby, Chuck Faust, Bill & Tomi Faust, Walter and Roxy Faust, Bill & Sue Hansen, Gary Karr, Dave & Sherill Kelsen, Don & Joan Minnick, George & Ruth Sawyer, Mark & Linda Sawyer, Dan & Diane Seeman, and Norman & Maritza Thrush. Ten Year Awards went to Joe Ambrose, Paul Hastie, and Duane & Ginny Ludtke. Fifteen Year Award was presented to Carol & Terry Thrush. Twenty Year Award for Jean Anderson, and Twenty-five Year Awards to Jerry & Sue Abbott, Valarie Basham (Life Member since 2009) and Reen & Sue Kotas. Thirty Year Award to Sue Winnett. Congratulations to all of these wonderful members.

Tour Director: Bud Swartwood thanked club members for their wonderful participation on tours this year and presented dash plaques to those who did their first tour. 500 Miles Awards were given to Steve & Ladd Graham, Roger & Eleanore Phillips, and Ron Polk. 1,000 Mile Awards went to Paul & Patty Winchester, Bud & Judy Swartwood. A 25,000 Mile Award was presented to Reen & Sue Kotas. Total Participation Award went again this year to Gene Amy who is always present at all tours, parades, and other activities. Congratulations again this year Gene. Way to go!

Committee Chairmen Recognition: Dave Sohr thanked Chuck Faust, Carol Weckman, Penny Smiley, Burnette Hill, Karen Wittkop, Reen Kotas, Rich Phillips, Valarie Basham, and Ray & Judy Jo Beardslee for all of their help this year as Committee Chairmen and welcomed new Committee Chairmen Roger Phillips-Membership, Billie Bonnoront-Fashions, Penny Smiley-Historian, Dalene Jensen-Refreshments, Diane Seeman-Corresponding Secretary, Reen Kotas-Property, Rich Phillips-Ways and Means, Ray & Judy Jo Beardslee Rec. Rep., Defender, Mailbox. He then thanked Board of Directors Danny Machado, Joan Minnick, Bob Weckman, Ron Peterson, Bud Swartwood, and Ed Woodruff for their help this year.

New Board Members Installed: Director Bud Swartwood, Assistant Director Paul Winchester, Secretary Bob Weckman, Treasurer Roxy Faust, Technical Arlyn Bieber, Tours Roger Ball, Past Director Dave Sohr.

Director Presentation: Danny Machado presented Dave Sohr with a Model "A" Driving Coat as a thank you from the club for his hard work and dedication to the club as Director the last two years. Thanks Dave for all you have done for our club.

Door Prizes: Many thanks to Valarie Basham and Jimm Kiklis for their wonderful job at providing door prizes.

Table Decorations: Penny Smiley and Valarie Basham did an outstanding job. The tables looked beautiful.

Slide Presentation and License Plate Game: Thanks again Penny and Valarie for a fun game and a great slide presentation of our 2009 club activities.

MAFCA: Arlyn Bieber talked about the MAFCA Million Mile Challenge and asked all members to record their odometer mileage, and send it to Roger Ball who will keep track of member mileage this year. Should be fun to see how many miles our members cruise in their Model A's this year.

Photo Contest Winners: Penny Smiley presented awards to Joan Minnick for location photo, Judy Jo Beardslee for Best Memory, Cars, and Members and the Funniest Award and Grand Prize Winner was Valarie Basham for her JEFFE coming home from Laughlin on a trailer.

Membership Drawing: \$50 went to Jerry & Maureen Kelly. Congratulations.

Next month, the Kitty will be \$10 so come on out to the meeting.

Meeting adjourned sometime before everyone left.

Respectfully Submitted Joan Minnick Recording Secretary

HAPPY
VALENTINES
DAY



TOURS: Roger Ball

JANUARY 30, 2010: After a week when rain, wind, and generally nasty weather caused a rain-out of the first tour of 2010, 40 members in 23 Model A's cashed in a Rain Check and participated in a "Follow-the-Leader" tour on January 30th.

The weather cooperated; the sun was bright and the streets were dry for our excursion. Starting from the IHop parking lot in Mission Valley, we headed south, up Texas Street then drove through San Diego neighborhoods that were young when our cars were new. We traveled through University Heights, Normal Heights, Kensington, and Talmadge before heading west along "The Boulevard" (El Cajon Blvd.) and Washington Street through Hillcrest.



All along the way we were greeted by smiling and waving residents, families, shoppers and outdoor diners, many of whom were taking pictures with cameras and cell phones. The group made its way, without any incidents, to Liberty Station, the historic Naval Training Center in Point Loma. We assembled for photos alongside the famous USS Recruit (aka USS Goes Nowhere) and then headed for lunch. Thanks to all for making this a fun event and such a successful first tour of the year!

Mileage to: Wehrle's, Bieber's, Stelzer's, Faust's, Schuler's, Hansen's, Ron Polk, Dave Sohr, Gene Amy, Valarie Basham, Ernie Mittemeyer, Machado's, Weckman's, Phillips', Swartwood's, Beardslee's, Ed Woodruff and Peggy Dalby, Melden's, Winchester's, Joe Ambrose, Ball's, Kaiser's, Seemen's and participation award to Roy Jensen.

UPCOMING TOURS:

Several tours are in the planning stages including a joint tour with the Harbor Area MARC/MAFCA and Capistrano Valley A's, a return overnight trip to Idyllwild, and a joint tour with the Palomar A's.

We have also been invited to participate in a display with the San Diego Antique Airplane Association at Gillespie Field on February 20th and we may include a short tour with that event. Look for details soon and sign-up at the club business meeting on February 12. Please contact Roger Ball (619-465-4110, rball@rickengineering.com) with any ideas for tour events and/or sign-up to lead a tour.



PARADES: Paul Winchester



There are no scheduled Parades for February 2010. The first Parade of the year will be the Ocean Beach Kite Parade on March 6th. We will meet at Toys-R-Us parking lot at 1240 West Morena Blvd, departing about 12:00 pm and driving to Ocean Beach for a 2:00 pm parade start. Arriving early will give us time to walk around and get lunch if you want to. The Parade route is down hill so be sure your brakes work, it could be cool and windy so bring a sweater or jacket. I hope to see you there it is always a fun parade, the people of Ocean Beach enjoy seeing us in their parade. Actually, I think the OB residents just like an excuse to stand on the sidewalk and yell.

We will not be attending the St. Patrick's Day Parade in San Diego this year. The parade organizers wanted \$50.00 and would only allow 4 cars to enter, no exceptions.

Dear Friends,

Annual dues time is here again and it's time to make a decision. As I look back over the last year or so, it appears I could count on one hand the club functions I have attended. Therefore, I will not be renewing my national or San Diego membership in 2010. I'll miss all of you; you're a great bunch of people.

This doesn't mean I'm no longer "car crazy". My three antiques get so much everyday use now that the modern usually has a dead battery when I want to use it. I also have twenty years of AACA and thirty years of Restorers magazines to read through.

So, goodbye to you all for now. If you should ever get as far south as Chula Vista please drop in on me. I'm usually in the back yard.

See ya on down the pike, Dean Tennis



PLEASE SAVE THIS DATE

June 26th, 2010



A very special couple will be married this June 26th, 2010. Eight closed Sedans will be needed. This promises to be a special day with lots of picture opportunities including at the Hotel Del which is the wedding spot, and dinner served to all the drivers. Parking at all locations have been arranged. I am not totally sure of the exact time frame yet but there should be no issues with getting home before the sun goes down. Josh and Daniela would love so much to have our cars for their special day and will be making a donation to the club. I have known Josh since he was just a little tot and look forward to helping this be the day they are wishing for. Anyone that can help out please contact me either through e-mail or phone.

Penny Smiley 619-440-0374 or email: dmsohr@cox.net

Tires, Tires and more Tires

During the 4 Model A production years four companies supplied tires for Ford's assembly line. They were Firestone, Goodyear, B.F. Goodrich and U.S. Rubber. Everyone has heard of Firestone, Goodyear and Goodrich but what do you know about the U.S. Rubber Tire Company? Here is a history of that Company.



Charles Ranlett Flint (1850-1934) involved himself in the rubber trade between Brazil and the United States in the late 1800s. During this same time frame the big business was rubber footwear. In 1892 Mr. Flint joined 11 firms and created the United States Rubber Company. This new company immediately controlled half of the nation's footwear sales. By 1898 the United States Rubber Company increased its market share to 75% but was turning only modest profits. By 1900 the rubber industry was rapidly shifting its focus to tire manufacturing for the automobile industry. By 1905 the new tire market was starting to turn high profits and companies competed heavily for top market shares. In late 1905 Charles Flint entered the tire business by buying Rubber Goods Manufacturing Company, one of the top tire producing companies at the time.

The DuPont family took control of U.S. Rubber in 1927 just as the first Model A rolled off the assembly line. In 1929, because of the Great Depression, tire sales dropped by two-thirds and suppliers lowered

prices for car manufacturers in order to maximize sales. U. S. Rubber continued to thrive mainly because they supplied half the tires for General Motors and a large percent for Ford.

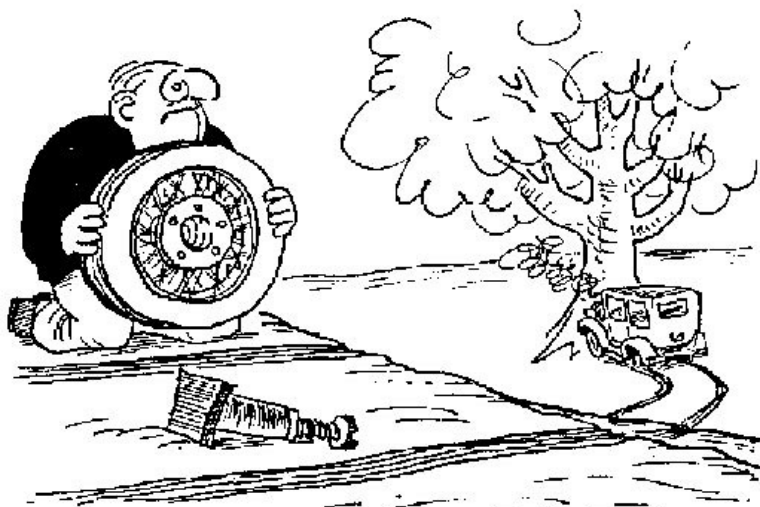

For the next 4 decades U. S. Rubber held a key position in the tire industry and in 1966 changed its name to Uniroyal. In 1986 Uniroyal and Goodrich merged their tire operations to form a jointly owned Uniroyal Goodrich Tire Company. A French Company, Michelin, purchased the Uniroyal Goodrich in 1990. Come to the next meeting and learn more about Model A tires and see a genuine U. S. Rubber tire from the 1930s.

TECHNICAL WORKSHOP

BUILDING A LEAKLESS MODEL A WATER PUMP

Are you tired of greasing your water pump or cleaning your firewall because your water pump leaks? If so, plan to attend a technical workshop demonstrating how to build a leakless water pump that doesn't have to be greased. The workshop will be held on Saturday, **February 13th at 9:00 AM**. The location is the **HANSON FORD GARAGE** at 14755 Mussey Grade Road, Ramona, CA. All Model A enthusiasts are invited to attend and enjoy some ole fashion tire kickin' fun.

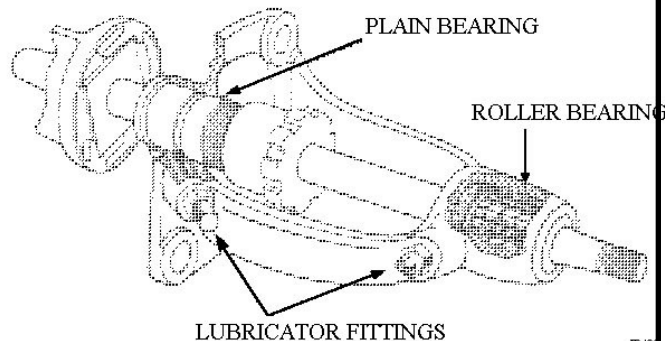

1928 ERA FASHIONS 1931

Billie Bonnoront

HEADGEAR

HOW TO KNOW YOUR VINTAGE FASHION ERA

Trying to find the correct Era style you are looking for can be a challenge due to hat shapes that changed very quickly from 1928 through 1931. Fabrics such as straw and horsehair braid were usually warm weather fabrics. Velvet and fur were seen in fall and winter. Felt was worn year round and satin was seen on more elegant hats and also used as a trim on simpler models. Millinery colors were as varied as styles. Brown and black were always popular, followed by navy, green, sand or beige. Other common colors, especially in spring and summer, were white, paler shades of rose, spring green, light blue, grey, peach and pink. Unusual colors, such as chartreuse or purple were worn to compliment special outfits. The color of a hat chosen for an outfit usually either matched the main dress or coat, color, or complimented the accessories.

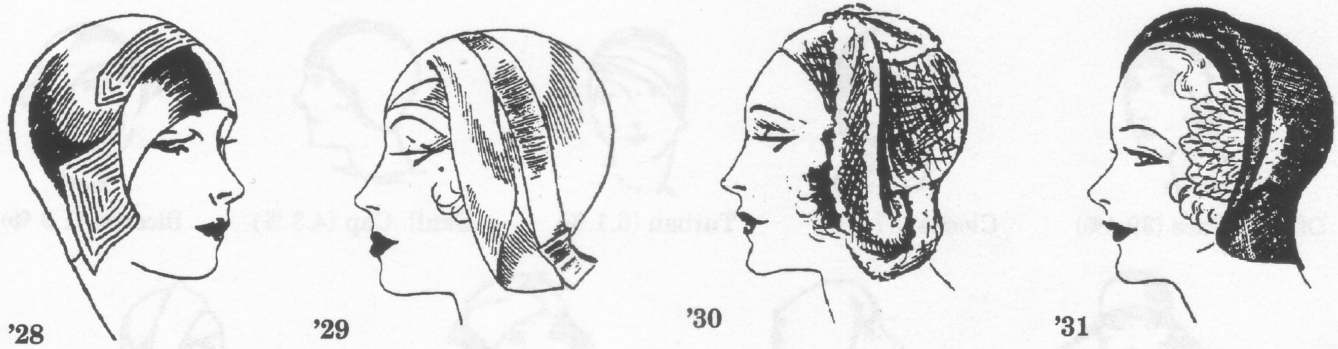

Compare hats of basically the same type from 1928 through 1931, and note how they changed. The hat is worn covering the eyebrows in 1928, showing the eyebrows in 1929, exposing the forehead in 1930, and showing the forehead and hairline in 1931. *MTR*, January 1928, December 1929, January 1930, and May 1931.

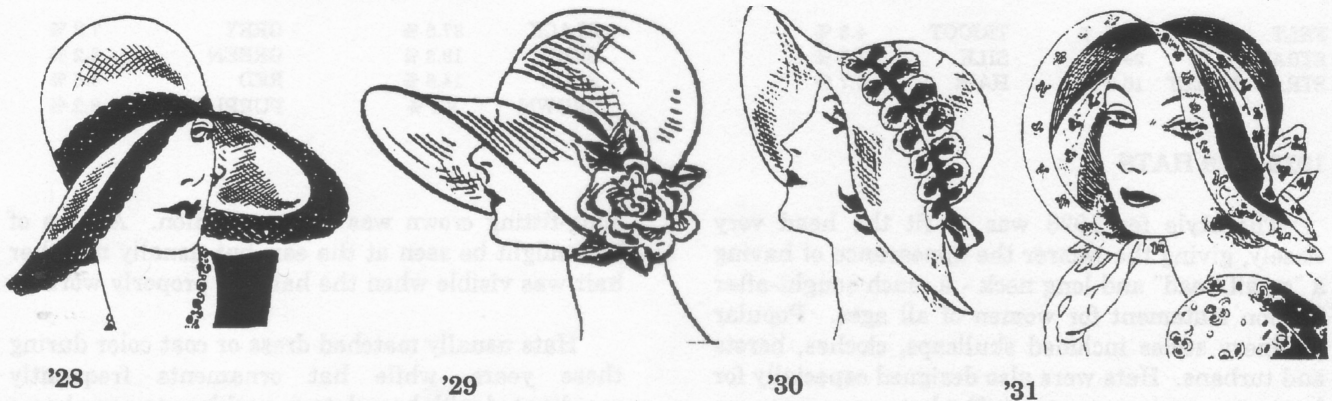

These large-brimmed hats illustrate the changes in crown depth, very deep and covering the eyebrows in 1928, and becoming much shallower in the later years, showing more forehead. *MTR*, May 1928, January 1929, December 1930, and June 1931.

MAFCA MILLION MILE CHALLENGE

Make sure you have given Roger Ball your Model A odometer reading so you can be part of the Million Mile Challenge this year. Each participant will be rewarded with a window decal noting that they were part of the MAFCA 2010 MILLION MILE CHALLENGE. Progress will be reported on the MAFCA web site (www.MAFCA.com) as well as in *The Restorer*

**The Model A Ford Foundation, Inc. (MAFFI)
P.O. Box 95151
Nonantum, MA 02495**

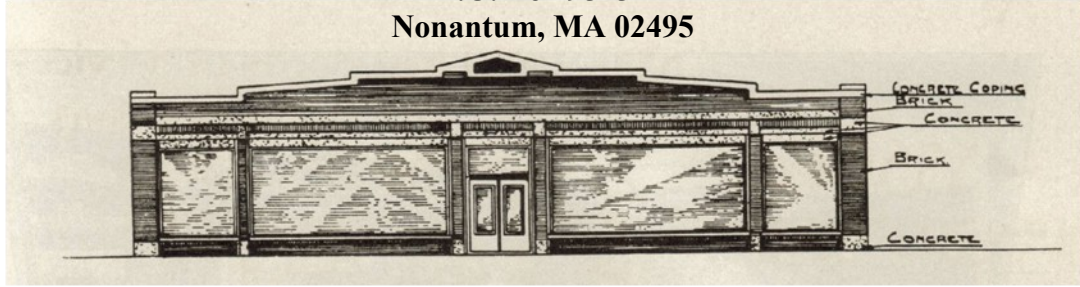

Dear Museum Liaison Member: (Arlyn Bieber)

Welcome! We hope you are as enthused as we are about the prospect of a National Model A Museum. Also we want to thank you for agreeing to help us make it happen. We need to keep everyone informed about what we are doing, and get your club's ideas and advice about the major decisions facing us.

As you may know, MAFFI has existed for over twenty years working to reach this point. **The goal from the very beginning has been to establish a museum.** That goal is what allows us to be an IRS 501c3 organization to which donations of any kind are tax deductible. That is how we are different from MARC and MAFCA.

So what is the situation at present? Foundation Trustees looked for years for a museum location and have recently decided on the Gilmore Car Museum in Michigan. It is an established, high-quality museum that has all the administration already in place – security, maintenance, visitor reception and ticketing. All we have to do is build a building and fill it with displays. A big task, but doable with people like you helping.

We have sent a letter of intent to Gilmore telling them that we plan to enter into an agreement with them for the museum. We have not yet negotiated the final agreement, so there is the slight possibility that we would be unsuccessful and end up at another location. But our intention is to work hard to reach an agreement with Gilmore. If you

aren't familiar with the Gilmore museum, you can look at their web site at <http://www.gilmorecarmuseum.org/>

While we have been talking with Gilmore we have also been thinking about the design of the museum building. We found a recommended Ford Dealership building design published by Ford in 1929 (see the image in the letterhead). We have explored the idea of adapting the design to a modern pre-engineered metal building. A final decision on the design has yet to be made, in fact another building design is also being reviewed, just to make sure we pick a building style that is functionally correct and historically significant.

MAFFI now owns eight vehicles. That is a fine start, but much more will be needed – additional cars, displays of parts, accessories, tools and fashions. We are hoping that clubs around the country will take on the various tasks of making displays, loaning cars, and researching historical records.

If you would like to share this letter with other members of your club, even reading it at a meeting, please feel free to do that. We want all Model A'ers to be enthused and involved.

Again, many thanks for you role in the Model A Museum.
Stanley R. Johnson, Secretary

Membership in Attendance:

Congratulations to Jerry & Maureen Kelly. Maureen gladly collected the \$40.00 last month then made a fast get away before Jerry could get to the front of the room. The pot rolls over to 10 bucks again this month. See you at the Feb. 12 meeting.



\$10



'31 Deluxe Roadster, new engine, radiator, differential, brakes and high compression "Winfield" head. Great condition, mechanically sound, tour ready. \$19,500 Walter Faust 619-297-1424

1929 RUMBLE SEAT COUPE: Rebuilt engine & transmission. New tires & powder coated wheels. Complete brake rebuild including new cast iron drums. Complete front end rebuild including king pins, straightened axle, steering balls, new front spring. Steering box rebuilt. New Lebaron Bonney interior upholstery. All work performed by Hansen Ford garage. \$14,000 Walt Miller, El Cajon, CA, Tele. # 619-442-4726, cell 619-977-1707

Very nice trunk off of my 1931 coupe. Purchased from Snyders in 1990. Will sell to club member for \$150. or see it at Big 3 for \$200.
Mike Miley 619-670-5509

1929 4Dr. Briggs, steel back, straight excellent body. 16" wheels. Original top & interior located in Solana Beach area. \$3,000. firm.
Ray Beardslee 619-465-9513

BANQUET DOOR PRIZES

I want to thank Jimm Kiklis for collecting door prizes in the east county area of town, and helping me at the banquet with the distribution of those prizes. I took the money provided by the club and purchased a number of gift cards; they were added to a wide variety of gifts donated by club members. A special thanks to the following club members for making donations: Ron Polk, Rich & JoBeth Stelzer, Ray & JudyJo Beardslee, Jimm & Sharon Kiklis, Jerry & Maureen Kelly, Dave & Sherrill Kelsen, Bill & Meripa Corson, Ed Woodruff & Peggy Dalby, Bill & Sue Hansen (Hansen's Garage), Jennifer R. (Abbott's granddaughter), Karen Wittkop, and myself.

Thanks Valarie Basham

REFRESHMENTS: Dalene Jensen

Valentine Treats!!!

Valerie Basham
Dave Sohr
Sharon Kelson

Billie Bonnoront
Danny Machado
Ron Polk



February Birthdays

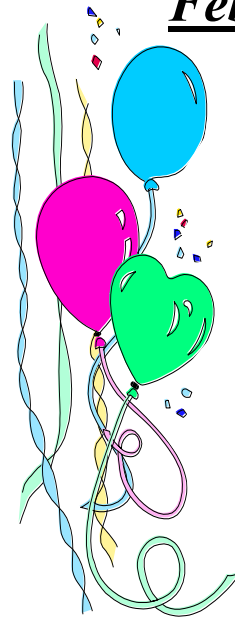

- 2 Jay Zamzow
- 4 Walter Faust
Mike Miley
- 7 Julie Loftus
- 13 Carol Thrush
- 15 Bill Faust
- 22 Julie Walstrom
- 23 Jean Anderson
Vern Schwebke
Phillip Terzich
- 25 JoBeth Stelzer
- 26 Luci Fowers
- 27 Rob Roland
- 28 Sharon Kiklis
- 29 Dalene Jensen

February Anniversaries

Dan & Diane Seeman Feb. 7, 1959
Roger & Jill Kerr Feb. 11, 2001
Tim & Sonya Hill Feb. 2, 2002



2010 MEMBERSHIP ROSTERS

The new 2010 roster will be available at the February meeting. They will not be sent out, but you can pick one up at the meetings and other club events for the next few months. One copy is free to each family, additional copies can be purchased for the cars, the garage phone, etc for just \$1.00 each. See Valarie Basham to get your 2010 roster.

Bill Hansen's

Model A Ford Service & Repair
Proudly using KR Wilson Tools for
Dealership Quality



14755 Mussey Grade Rd Day 760-789-8296
Ramona, Ca. 92065 Evenings 619-461-1001 E-
mail lamesla@yahoo.com

Complete Rebuilding of: Engine, Transmission,
Clutch, Rear end, Front End, Steering Box & Brakes.
Other Services: Wheel Balancing, Counter Bal-
anced Crank Shafts, Engine Babbitting, Lightened
Fly-wheels, V8 Clutches, Leakless Water Pumps,
Carburetors, Distributors, Generators, Starters and
more.

CALL FOR COMPLETE LIST OF SERVICES!

"The best place in town to take a leak"

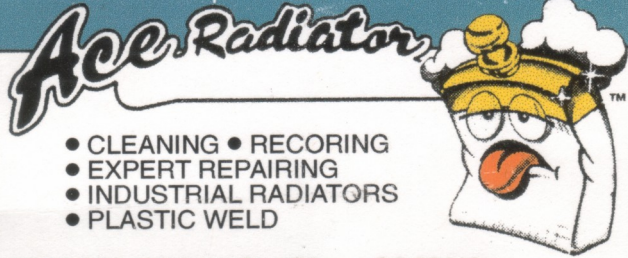

- CLEANING • RECORING
- EXPERT REPAIRING
- INDUSTRIAL RADIATORS
- PLASTIC WELD

1836 National Ave., San Diego, CA 92113

Chaney Silva (619) 233-8811



Wood Graining & Custom Automotive Painting

Mohogany • Butwood • Walnut
Pearl & Kandy
Finishes



David J. Garcia



(619) 723-3805
La Mesa, CA

E-Mail
superdavegarcia@hotmail.com

S
U
P
P
O
R
T
O
U
R
A
D
V
E
R
T
I
S
E
R
S

Body
Paint

Mechanical
Wood

Webb's Auto Repair & Restoration

Antique & Modern
WEBB H. SMITH

5644 Loping Lane
Bonita, California 92002
619-479-9567



Rich Phillips Auto Service

Complete Auto Repair

Foreign & Domestic

7105-B El Cajon Blvd.
San Diego, CA 92115

Certified Technicians
(619) 463-3315

Generators
Starters
Regulators

Batteries

Solenoids
Alternators
Remanufacturing

Broadway Auto Electric

7825 NORTH AVENUE
LEMON GROVE, CALIFORNIA 91945

RICK ZITREN

(619) 461-4555
FAX 461-4899

OLD CARS & PARTS

SINCE 1986



Street Rods or Original

619.449.0551

10011 Prospect Ave. • Santee, CA 92071

Hank

LINES & DESIGNS by Robert Gagnon

Hand Painted Pinstriping

Custom Artwork & More



619-889-8588

www.Ldbyrg.com

SCAM ALERT !

A "heads up" for you guys who may be regular Home Depot customers. This one caught me by surprise. Recently I became a victim of a clever scam while out shopping. Don't be naive enough to think it could not happen to you or one of your friends. Here's how it works: Two seriously good-looking 20-21 year old girls approach your car as you are packing items into the trunk. They both start wiping the vehicle's windshield with a rag and window cleaner, with their breast almost falling out of their skimpy T-shirts. It is nearly impossible not to look. When you thank them and offer a tip, they say "No" and instead ask for a ride to the nearest McDonalds. You agree and the get into the back seat. On the way, one of them climbs over into the front seat and starts crawling all over

you, while the other steals your wallet ! In December 2009 I had mine stolen on the 4th, 9th, and twice on the 15th. Already this year I was victimized Jan. 1st and 4th, three times last Monday and very likely again this coming weekend...So tell your friends to be careful.

P.S. Walmart has wallets on sale for \$2.99 each. --- I found cheaper one at Dollar General and bought them out. Also, you never will get to eat at McDonalds. I've already lost weight just running back and forth to Home Depot...

Just looking out for my fellow Model A guy members... Bill Corson

1928  1931

M.A.R.C./M.A.F.C.A. of San Diego
P.O. BOX 19805
San Diego, Ca. 92159

FIRST CLASS POSTAGE
DATED MATERIAL ENCLOSED
ADDRESS CORRECTION REQUESTED